



ver 3.0 updated 2008-07-08 22:00

Race PM/ News letter GHAR 2008

The start of GHAR is quickly approaching (July 12, at 00:01) We have put all the information that you require together in this PM / news letter. Please note that there are several sections to this PM and you need to read it trough carefully. We however recommend that you ASAP go through the course description just to get a flavor of what lays ahead. In the race direction we are happy to say that we would love to race this course ourselves.

Very welcome to Gothenburg and GHAR 2008.

For the latest news or if you have any additional questions please use our race homepage and forum at www.ghar.se.

Contents

General Information	2
Important times to keep track of.....	5
Course description.....	6
Standard course	6
Short course	7
Rules & Equipment	8
Logistics	11

Note! If you are bringing your own paddles and life jackets and/or want extra maps please report this to info@ghar.se ASAP but no later than June 27.

General Information

How to get to the race

The pre-race meeting of GHAR 2008 will be held at Herkulesgården in Mölndal outside Gothenburg. You can find a map with driving directions by going to www.eniro.se and type in Herkulesgården, Mölndal.

Parking

One car per team will be allowed to park at the TA in Herkulesgården. If you come with more than one car you might have to find parking somewhere else.

Valuables

One bag per team containing valuables etc can be stored in a locked room inside Herkulesgården. Herkulesgården will however not be manned during the whole race so if possible try to store valuables somewhere else.

Start envelope

You can pick up your start envelope between 18:00 and 19:30. Your start envelope includes a "punch card", 2 bib vests, complete set of maps + extra set of maps if ordered extra (order at info@ghar.se before June 26) and road book with detailed control descriptions. You will also receive three 120 liter plastic bags that should be used to check in energy, extra clothes and equipment that should be used during the race.

Skill check

There will be a rope works (descending) skill check for all competitors at Herkulesgården 18.30 to 22.30 on Friday.

Pre-race meeting

We will have a short obligatory (It is mandatory that one member of each team is present during the meeting.) meeting at 20:00 in Herkulesgården to go through the race PM and maps. There will also be time for questions.

Remember to also bring food to eat until the start of the race. A pasta salad could be good to snack on while preparing for the start.

Check-in and check-out of equipment

Equipment, including MTB, can be checked in from 21:30 and has to be checked in before 22:30 on Friday 11 July. Further details of check-in will be explained during the pre-race meeting. Remember to mark all equipment before the race.

It is important that you carefully plan what gear and what energy that you bring with you. The TA personnel will keep an eye out so that you check in an out the right equipment but the responsibility is entirely yours to make sure that you bring what is needed.

For more information on when to check-in gear, energy and equipment visit:

http://www.ghar.se/course_and_packing.htm or see attached logistics description at the end of this document.

Race start

The race starts at 00:01 on July 12 but since you will be transported by bus to the starting line you need to check in all equipment before 22:30 and be ready to go at 23:00.

Price Ceremony

Price Ceremony will be held at Herkulesgården close to the finish of the race. Exact time will be announced as you cross the finish line.

Short course and cut-offs

For the all-women teams and the “slower teams” there will be a shorter course. There will be cut off times at some TAs. If your team fail to make it to these TAs before the cut off time you'll be considered a “short course team” and forced to take the short course. The cut off times will be clearly stated in the road books. A team that has been forced to take the short course will always be ranked below any team fulfilling the ordinary course (not applicable to the women's class).

Price Ceremony and prices

The Price Ceremony will be held at Herkulesgården as soon as results are official. Exact time will be announced as the winners of each class cross the finish line.

Price money will only be paid out to club or company. Price money will be divided between the winning teams based on the percentage of teams starting in that class.

The price table will also consist of other prices from our sponsors.

Control points (CPs)

The race consist of several control points. All control punching is done manually. Both team members must touch the control, unless otherwise stated in the road book. Lost punch card means immediate disqualification. The distance between team-members must never exceed 30 seconds unless the Road Book or the race directions says otherwise

Transition areas

The race organization will make all necessary transports of your gear. It is therefore important that everything is clearly marked. Also remember to check-in everything before leaving a TA. Your MTBs will be transported in sealed trailers. We promise and insure that we will treat your MTBs and gear as if they were our own but the race organization can not take responsibility for damaged MTBs or gear. If you want to pack your MTB in bag/box for protection that is ok but please remember that the bike needs to be packed before check-in at all relevant TAs.

TA personnel will not collect gear that you have not checked-in!

On TA's you can fill up on water and in some TAs also visit a toilet. The race organization will not provide you with any energy at TAs. The teams are self supported.

Support

Remember that this is an unsupported race which means that you have to bring everything with you or plan for this by packing it in the three 120 l plastic bags that the race organization provides you with. No support allowed.

All energy, food and drinks have to be brought by the racers or packed in the equipment bags. Water is available at TAs. Food can be purchased close to Herkulesgården before the race and in some sites along the course as the race has started (depending on when you pass these stores – if you pass in the middle of the night we wish you good luck!)

The race organization will try to arrange that there are some snacks available at limited cost in Herkulesgården as you cross the finish line.

Insurance and liability

Participants are protected by Folksam K-96

All participation is done at the own risk of the racer. Agreements where this is acknowledged has to be signed before the race. (Minors need form signed by parent/guardian). By signing this agreement the racer acknowledges that he or she:

1. Races at own risk.
2. Is responsible for the team canoe and will have to cover costs for loss or damage of canoe, paddles, life vest and/or canoe cart.
3. The race organization will not be held economically responsible for loss or damages to checked-in equipment
4. The racer will follow traffic rules and other applicable Swedish laws.

Withdrawal

Teams who withdraws from the race have to report that to the Race Direction immediately – teams are responsible to transport themselves to the next TA. The race direction will however try to find means of transportation. The Race Direction reserves the right to withdraw a competitor from the race if his/her health is in danger.

In case of emergency

In case of emergency teams must support each other until help arrives. If serious injury call 112 for ambulance before alerting the race direction. If minor injury call race direction as specified in road book.

Shower and sleeping possibilities

After the race you can shower at Herkulesgården. If you bring a tent you can camp outside Herkulesgården after the race. We will also dedicate a limited area in Herkulesgården where participants can rest in their own sleeping bags on the floor. But remember that Herkulesgården is small so everyone will not fit.

Reporting and results

All teams in GHAR will carry GPS and can be tracked via Multisport Live. We will also have live coverage with times and reports from the course on www.ghar.se

Important times to keep track of

Friday June 27

Send mail to Race organization stating if you will bring own paddles and life vest. Also last day to sign up for extra maps at an additional cost of 200kr.

Friday July 11

18:00-19:30 Herkulesgården opens and you can collect you start envelope

18:30-22:30 Skill check

20:00-20:40 Pre-Race meeting

21:30-22:30 Check in equipment, extra clothes and energy

23:00-23:15 Bus leaves from Herkulesgården

Saturday July 12

00:01 Start GHAR 2008

Sunday July 13

00:01 First team hits the finish line

12:00 Last team hits the finish line and the finish closes

Course description

(You can find some pictures from the course at www.ghar.se)

Standard course

The course consists of a prologue and seven different stages as listed below:

START-----

Prologue (Inlines/Trekking) 22 km ~ 2h

TA 0 (Arrive/Depart)-----

Stage 1 MTB 52 km ~ 2h 30 min

TA 1 (Arrive)-----

Stage 2 Trekking 8 km ~ 1h

TA 1 (Depart)-----

Stage 3 Canoe 31 km ~ 3h 30 min

TA 2 (Arrive)-----

Stage 4* MTB 64 km ~ 3h
Stage 5* Trekking 10 km ~ 1h 30 min

TA2 (Depart)-----

Stage 6* Canoe 30 km ~ 3h

TA 3 (Arrive/Depart)-----

Stage 7 Inlines/Trekking 39 km ~ 4h 30 min

FINISH-----

* All-women teams and the "short coursed" teams will do shorter versions of these stages. These are described in the chapter "Short course".

The competitors will be transported to the start (somewhere on "Sveriges framsida") by bus departing from Herkulesgården at 23:00.

Prologue:

The prologue consist of a short inlines/Trekking stage that will give the competitors a taste of the Swedish west coast and Gothenburg at night time. During this short prologue you will experience both rural coastal environments as well as urban areas. At the end you will wish that cross-country ski poles were allowed, but they aren't...

Stage 1:

This first MTB stage will be a fast ride at both tarmac and gravel roads. This will be a stage were strong riders can fully exploit their strength on the bikes, without being held back by the navigation. Many teams can benefit from using some kind of towing device on this stage.

Stage 2:

As usual the teams can choose to take either safe or fast route choices. If you have a good navigator in your team there won't be any problems finding the CP:s but if you're not as sure with the map, you

might want to consider taking a longer and safer route choice. If you get lost in this terrain it can cost you lots of time...

Stage 3:

From TA 1 the teams will start running with their canoes on trolleys. The teams will then start the paddle towards TA 2. Along the way there will be a few long lifts where the teams will run with their canoe on a trolley. It might be beneficial for you to practice this before the race in order to save time during this stage.

For one of the team member there will be an additional challenge along this stage, i.e. jumping from a cliff into one of the lakes. We hope you're not scared of heights...

Stage 4:

If the first MTB stage was fast and easy, this stage is the opposite. There are hills along this stage that are so steep uphill that we'll be surprised if you are able to ride your bike there. Compared to the first MTB stage this one is also a lot more technically challenging.

Stage 5:

Your legs will probably tell you to stop running. But if you fight the exhaustion and keep on running you'll have a good chance to cut a lot of time during this stage. The navigation is pretty easy, so if you feel good there shouldn't be any problems.

Stage 6:

After completing the previous Trekking your legs will be smiling when they can rest for a while in the canoe, except for during one short lift. There is nothing complicated with this paddle. Just feel the rhythm 3-2-1-Change.....3-2-1-Change.....3-2-1-Change.

Stage 7:

When you're coming closer to the finish line you'll feel stronger again. This Inline/Trekking stage is simply like walking a red carpet to the finish line. Inlines on nice cycle tracks will make the distance to the finish line diminish like a snowball in hell. Make sure you practice transition between inlines and running shoes before the race in case you have to sprint against another team on this section. Also be sure that your inlines can be fastened to your backpack so you don't have to carry them by hand when you are running. Almost forgot, there will be some rope-works on this section. Watch out, both competitors might get wet....

Short course

For the short course the prologue, stage 1-3 and stage 7 will be identical to the ordinary course. The exceptions will be section 4-6 as described below:

Section 4 (short):

This section is still a MTB stage but is only 18 km long and is expected to take about 1 hour and 30 minutes.

Section 5 (short):

This Trekking stage is just 6 km for the short course and will take the teams around an hour to complete.

Section 6 (short):

Instead of paddling between TA 2 and TA 3 the teams in the short course will ride their MTBs for about 2 hours. The total distance on this stage is 34 km.

Rules & Equipment

Team

- The team will consist of 2 competitors.
- Team-members names need to be reported at latest 12 hours before start.
- No changing of team members during the competition is allowed.
- Time-penalties due to breaking of the rules are up to the race leader's discretion
- Traffic rules and the trespass laws must be obeyed..
- The teams are self-supporting, but are allowed to buy gear and food during the race.

Checkpoints (CP)

- Along the course there are CP:s that have to be taken in right order.
- Teams must follow a marked route when instructed to do so.
- If a team misses a CP, the team has to backtrack to the CP. If not, the team will be disqualified
- Both team-members must touch each CP

Transition Area (TA)

- TA's is where the transition between different disciplines is made
- At TA:s you can go visit a toilet, fill up with water and you have the possibility to leave garbage. Here you will get access to mandatory equipment transported by the organization and your personal belongings packed in 120l plastic bags also transported by the organization. (Plastic bags marked A + B + C)

Race Time/Map

- Race time is in hours, minutes and seconds.
- The distance between team-members must never exceed 30 seconds unless the Road Book or the directions says otherwise.

Race direction

- The Race direction has the right to decide about time-penalties, disqualifications and course changes.
- All protests shall be written and given to the Race direction within two hours after the team reaches the finish line. There will be a SKR 500 cost for protests.

Withdrawal

- Teams who withdraw from the race have to report that to the Race Direction.
- The Race Direction reserves the right to withdraw a competitor from the race if his/her health is in danger.

Penalties

Disqualification will occur if:

- Littering
- Breaking the Safety instructions or if instructions from officials are not followed.

Time-penalty

Penalties will be taken for:

- Non-visible bib-vest.
- Missing equipment.
- Adventure activity not completed

Force Majeure

- The Race Direction reserves the rights to decide about questions that were not known when the rules where decided.

The course and maps

- After the teams have fulfilled the registration, skill check and equipment check the teams will receive Road-book and maps.

- It's compulsory to follow markings on the maps and the Road-Book.
- **Canoe:** It's compulsory to paddle on canoe stages. Lift is only allowed where marked on the maps. Life vest is compulsory.
- **Inlines:** Competitors skate on the right side of road. At night time headlamp is compulsory. Red taillight is mandatory during inlines in the dark. There might be combined trekking/inlines stages. Use of inlines only allowed where indicated.
- **MTB:** The MTB:s should be brought all the way to the CP unless otherwise stated on map and Road-Book. Swedish traffic laws apply - MTB with front and rear light (*the front light should be mounted directly on the bike, only headlamp is not allowed*).
- **Adventure activities:** Follow instruction from marshal. Organization will give you all the equipment you need.

Equipment

- GPS or similar equipment are forbidden.
- It's not allowed to leave any equipment, trash or waste on the course.
- The obligatory equipment shall be shown upon request from the organization. Penalty time will be taken at the checkpoint.
- Always wear the bib vest on top (even outside the life jacket) and please wear similar clothes.

Team equipment (mandatory from start to finish)

- First aid kit
- Compass
- Cell phone, water proofed
- Roadbook (*given by the organization*)
- Maps (*given by the organization*)
- Whistle

Personal equipment (mandatory from start to finish)

- Water bottle, Camelback or similar (min. 1 liter)
- Gloves, long fingers
- Tights or similar
- Long-sleeve sweater
- Water repellent jacket
- Water repellent pants
- Backpack (*min 20 liters recommended*) Should accommodate for inlines
- Head torch (*only at night time or if mentioned in roadbook*)
- Bib vest
- Bike helmet (*to be used during biking, inline skating and adventure sections*)
- Water proof bag

Personal equipment on special sections.

- Life jacket
- Mountain bike,
- Inline skates
- Bike helmet (*to be used during all biking and inline sections*)

Team equipment (on special sections).

- Spare tube, min. 2/team
- Bike tools
- Pump
- Canoe and canoe paddles

Recommended gear, team

- Bike pants
- Map holder on the bike

Recommended gear, personal

- 2 pair of running shoes. One on prologue and one from OL1. Unless you want to pack the first pair on MTB1. No transfer of equipment to TA1 after prologue.

Obligatory equipment (given by the organization)

- Road book (for competitors on track) to bring all the time.
- Phone list
- Maps
- Bib-vest to be worn all times, even on top of the life jacket.

Logistics

(This info also available at http://ghar.se/logistics_competitor321.xls)

Competitor perspective, standard course

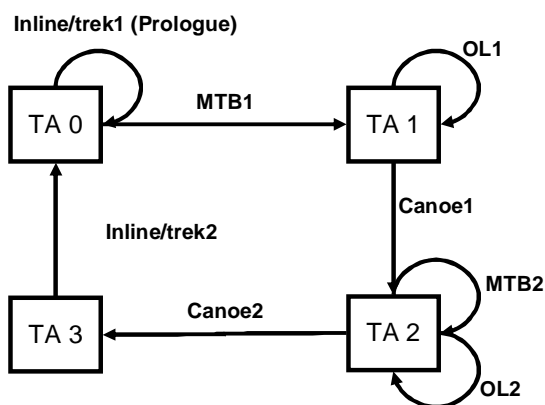

When	Where	Item	In/Out/ in canoe	Delivered to	Containing	Pick up at
Prior to prologue	TA 0	Sack A	Check In	TA 1	Paddles, PFD:s, running shoes, +	T + 4 --> T + 8 Hrs
Prior to prologue	TA 0	Sack B	Check In	TA 2	Nutrition, extra clothes, +	T + 8 --> T + 14 Hrs
Prior to prologue	TA 0	Bike etc for MTB1	Check In	TA 0	Everything needed for MTB1	T + 1 --> T + 2 Hrs
Prior to MTB1	TA 0	Sack C	Check In	TA 3	Inlines, +	T + 18 --> T + 30 Hrs
Prior to OL1	TA 1	Bike	Check In	TA 2		T + 8 --> T + 14 Hrs
Prior to OL1	TA 1	Canoe, cart	Check out	Competitor		
Prior to OL1	TA 1	Sack A	Check out	Competitor	Paddles, PFD:s, running shoes, +	
Prior to OL1	TA 1	Bikeshoes, helmet	In canoe	Competitor		
Prior to Canoe 1	TA1	Sack A	Check In	TA0	Things you won't use any more	
Prior to MTB2	TA 2	Bike, Sack B	Check out	Competitor	Nutrition, extra clothes, +	T + 8 --> T + 14 Hrs
Prior to Canoe2	TA 2	Bike	Check In	TA 0		After race
Prior to Inlines/Trek2	TA 3	Sack C	Check out	Competitor	Inlines+	
Prior to Inlines/Trek2	TA 3	Sack C	Check In	TA 0	Everything that will not be used for last stage	After race

Competitor perspective, short course

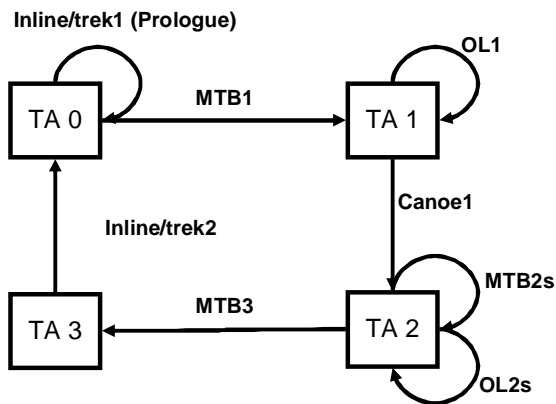

When	Where	Item	In/Out/ in canoe	Delivered to	Containing	Pick up at
Prior to prologue	TA 0	Sack A	Check In	TA 1	Paddles, PFD:s, running shoes, +	T + 4 --> T + 8 Hrs
Prior to prologue	TA 0	Sack B	Check In	TA 2	Nutrition, extra clothes, +	T + 8 --> T + 14 Hrs
Prior to prologue	TA 0	Bike etc for MTB1	Check In	TA 0	Everything needed for MTB1	T + 1 --> T + 2 Hrs
Prior to MTB1	TA 0	Sack C	Check In	TA 3	Inlines, +	T + 18 --> T + 30 Hrs
Prior to OL1	TA 1	Bike	Check In	TA 2		T + 8 --> T + 14 Hrs
Prior to OL1	TA 1	Canoe, cart	Check out	Competitor		
Prior to OL1	TA 1	Sack A	Check out	Competitor	Paddles, PFD:s, running shoes, +	
Prior to OL1	TA 1	Bikeshoes, helmet, etc.	In canoe			
Prior to Canoe 1	TA1	Sack A	Check In	TA0	Things you won't use any more	
Prior to MTB2s	TA 2	Bike, Sack B	Check out	Competitor	Nutrition, extra clothes, +	T + 8 --> T + 14 Hrs
Prior to MTB3	TA 2	Canoe	Check In			
Prior to MTB3	TA 2	Sack B	Check in	TA0	Things you won't use any more	
Prior to Inlines/Trek2	TA 3	Sack C	Check out	Competitor	Inlines+	
Prior to Inlines/Trek2	TA 3	Sack C	Check In	TA 0	Everything that will not be used for last stage	After race